

REVISION HISTORY				
REV	DATE	DESCRIPTION	ECO	BY
A	06-25-08	PRODUCTION RELEASE	11956	AK
B	06-23-10	UPDATE 3D MODEL & BOM	13343	TZ

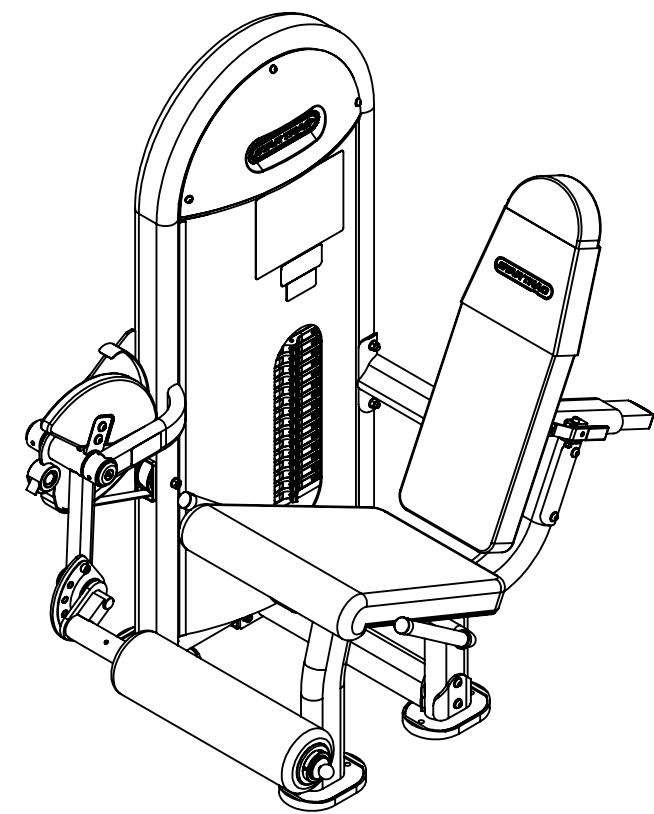
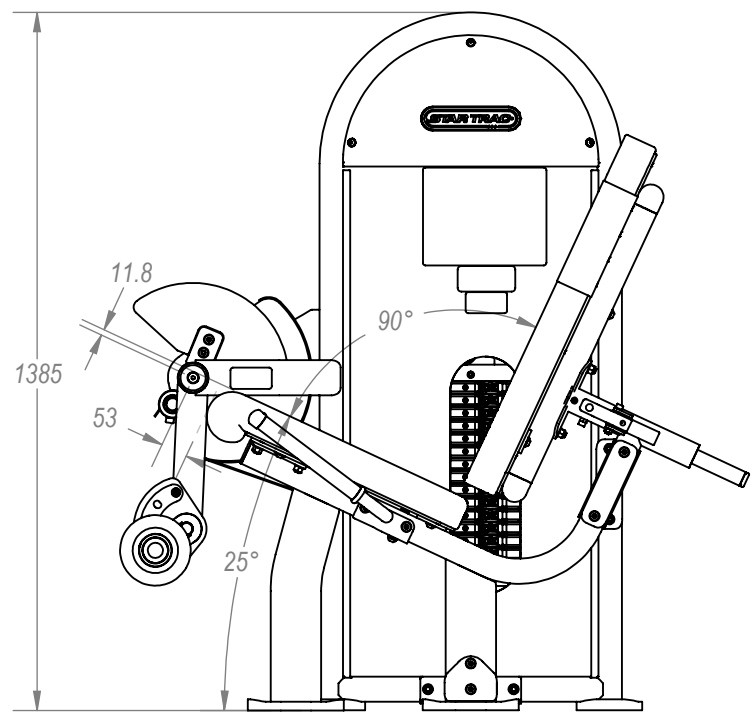
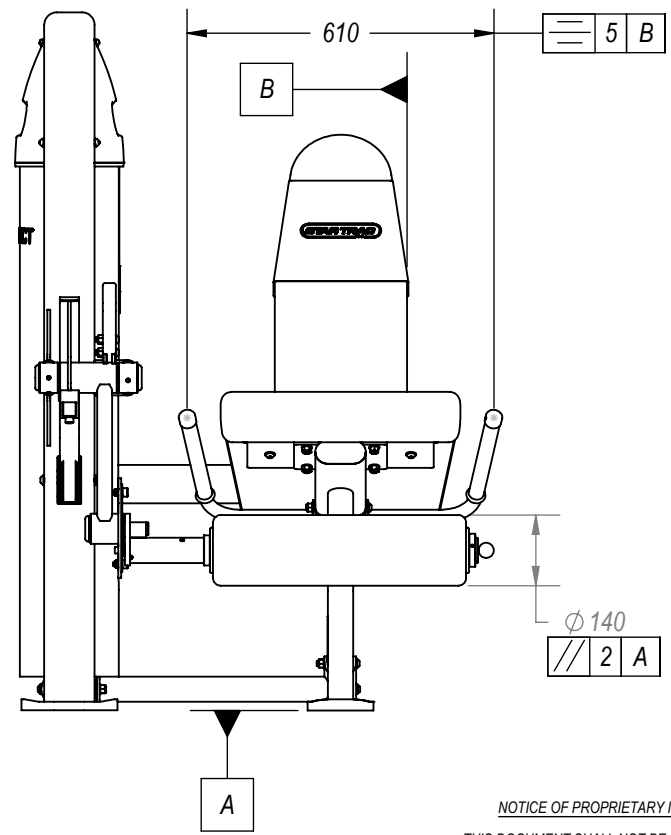
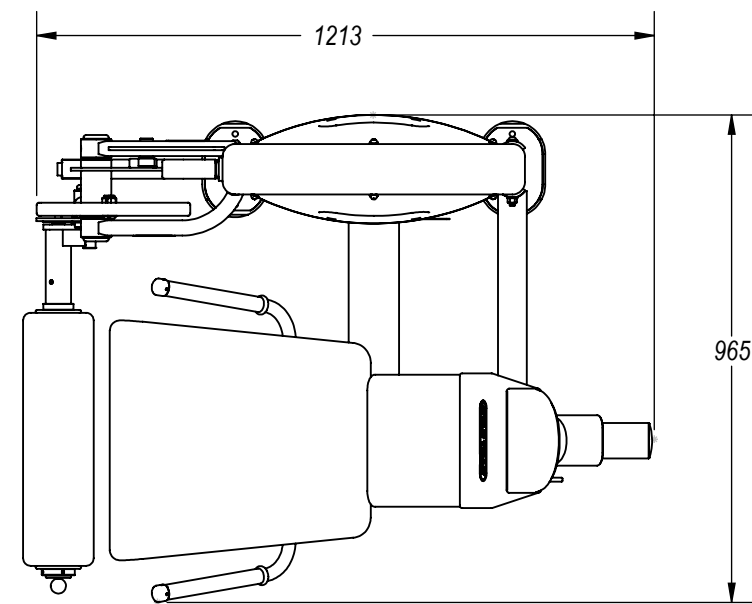

NOTICE OF PROPRIETARY INFORMATION
 THIS DOCUMENT SHALL NOT BE REPRODUCED NOR SHALL THE INFORMATION CONTAINED HEREIN BE USED BY OR DISCLOSED TO OTHER EXCEPT AS EXPRESSLY AUTHORIZED BY UNISEN INC, D.B.A. STAR TRAC.

DOCUMENT STATUS:

CLASS OF WORK	UNLESS OTHERWISE SPECIFIED DIMS ARE IN mm. TOLERANCES FOR MEASURE OF LENGTH ARE:							ANGLES = ±2°	MATERIAL SEE BOM
	0.5 to 3	> 3 to 6	> 6 to 30	> 30 to 120	> 120 to 400	> 400 to 1000	> 1000 to 2000		
FINE	±0.05	±0.05	±0.1	±0.15	±0.2	±0.3	±0.5	----	
MEDIUM X	±0.1	±0.1	±0.2	±0.3	±0.5	±0.8	±1.2	±2	FINISH
COARSE	±0.2	±0.3	±0.5	±0.8	±1.2	±2	±3	±4	FRAME COLOR: STAR TRAC SILVER (HP FULLER) UPHOLSTERY COLOR: STAR TRAC GREY (SLATE)
VERY COARSE	----	±0.5	±1	±1.5	±2.5	±4	±6	±8	VENDOR: IMPULSE P/N: IL-S1010

THIRD ANGLE PROJECTION		
DRAWN	INITIAL	DATE
CHECKED		
APPROVED		
	U.O.M.	MM

UNISEN, INC. DBA		14410 Myford Road Irvine CA 92606	
STARTRAC PART NO	REV		
9IL-S1010-13BSS	B		
TITLE IL,SSS,LEG EXT,SIDE MOUNT,LNL			
SCALE: 1:15	SHEET 1 OF 2	SHEET SIZE: B	

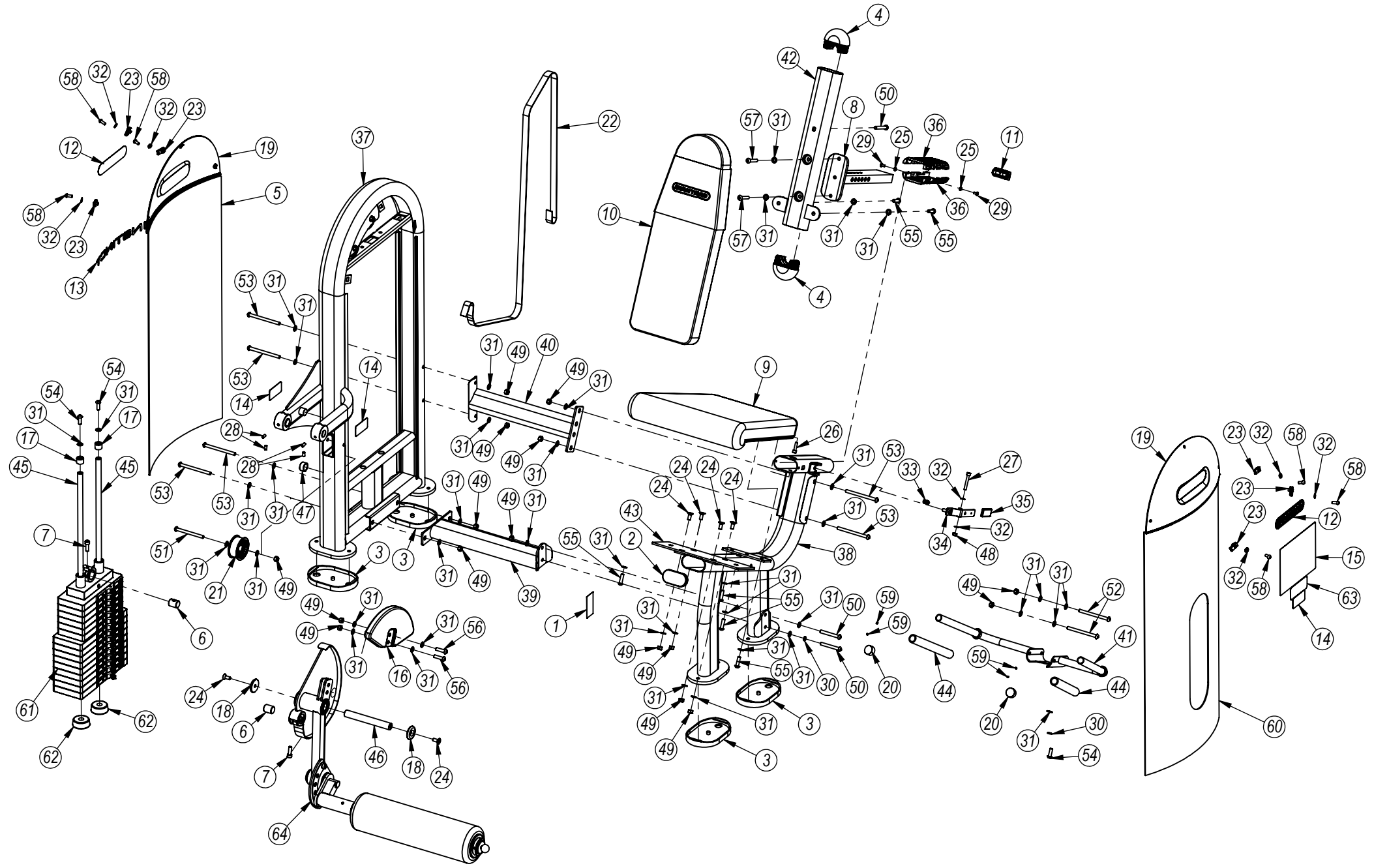

ITEM NO.	PART NUMBER	DESCRIPTION	QTY.
1	050-2125-02	LABEL, SERAIL NO, INSTINCT	1
2	730-0199	CAP, FLAT, ELLIPSE TUBE, 100X50	1
3	730-0216	PAD, FEET, BASE, IN-B7503	4
4	730-0223	CAP, LARGE, FRAME	2
5	730-0233	SHROUD, REAR, WGT STK, LP	1
6	730-0236	SHAFT, COMPRESS BELT, DIA 27, LEG 33	2
7	730-0237	SCREW, M10X1.5, 30MM, SHCS, HE, SS	2
8	730-0244	WELDMENT, SEAT POST	1
9	730-0245	PAD, SEAT, IN-S1011	1
10	730-0246	PAD, BACK REST, IN-S2100	1
11	730-0247	CAP, ROUND, SQUARE TUBE, 70X30	1
12	730-0383	STICKER, STAR TRAC, DECO, 196X45MM	2
13	730-0384	LOGO, INSTINCT	1
14	730-0385	STICKER, CAUTION, PINCH POINT	3
15	730-0399	PLACARD, INSTRUCTION, IN-S1010	1
16	730-0549	COUNTERBALANCE, IN-S1010	1
17	730-0565	CAP, RUBBER, ROD GUIDE WT STK	2
18	730-0656	CAP, 50MM OD	2
19	730-0702	SHROUD, TOP, LP	2
20	730-0704	CAP, OUTSIDE, GRIP, 25MM, AL	2
21	730-0721	PULLEY ASSY, DIA 76	3
22	730-0778	BELT, 15.5FT LONG, LP	1
23	730-0845	SPEED NUT, U-STYLE CLIP-ON NUT, M8	6
24	730-0870	SCREW, M10X1.5, 25MM, FHMS, HE, SS	6
25	730-0885	NUT, M6, JAM, HEX, SS	2
26	730-0891	SCREW, M8X1.25, 30MM, SHCS, HE, SS	1
27	730-0892	SCREW, M8X1.25, 55MM, SHCS, HE, SS	1
28	730-0896	SCREW, M8X1.25, 16MM, SET, EPS, HE, SS	4
29	730-0899	SCREW, M6X1.0, 12MM, PHMS, SS	2
30	730-0907	WASHER, M10, SPLIT, LOCK	2
31	730-0908	WASHER, PLAIN, M10, SS	47
32	730-0910	WASHER, PLAIN, M8, SS	8
33	730-0911	SPING, COMPRESSION, ADJ, HDL	1
34	730-0930	WELD, HANDLE, EXTENSION, ADJ	1
35	730-0935	GRIP, SQUARE, ADJ HANDLE	1
36	730-0936	ASSY, TUBE, INSERT, SLEEVE	2
37	730-1034	WEIGHT STACK, FRAME	1
38	730-1041	ASSY, MAIN FRAME	1
39	730-1042	CROSSBEAM, LOWER, FRAME	1
40	730-1043	CROSSBEAM, UPPER, FRAME	1
41	730-1044	ASSY, SEAT, HANDLE, FRAME	1
42	730-1045	UPHOLSTERY, BACK, PAD, BRACKET	1
43	730-1046	PLATE, SEAT, PAD, SUPPORT	1
44	730-1054	FRAME, SEAT, HANDLE, PVC, SLEEVE, GRIP	2
45	730-1078	GUIDE RODE, Ø19MMX935MM	2
46	730-1084	SHAFT, DIA 25MM X 192MM	1
47	730-1087	SPACER, DIA 32MM, HEIGHT 16MM	1
48	730-1103	NUT, M18X1.25, NYLOC, SS	1
49	730-1104	NUT, M10X1.5, NYLOC, SS	20
50	730-1109	SCREW, M10X1.5, 80MM, BHC, HE, SS	3
51	730-1110	SCREW, M10X1.5, 115MM, BHC, HE, SS	1
52	730-1111	SCREW, M10X1.5, 125MM, BHC, HE, SS	2
53	730-1112	SCREW, M10X1.5, 130MM, BHC, HE, SS	6
54	730-1118	SCREW, M10X1.5, 30MM, BHC, HE, SS	3
55	730-1119	SCREW, M10X1.5, 35MM, BHC, HE, SS	6
56	730-1120	SCREW, M10X40, BH, SS	2
57	730-1122	SCREW, M10X1.5, 63MM, BHC, HE, SS	4
58	730-1138	SCREW, M8X1.25, 20MM, BHC, HE, SS	6
59	730-1155	SCREW, 10-32X3.2, SET	4
60	730-1335	SHROUD, LNL, S5100	1
61	730-1399	WSA-LNL, 180LB, 15H	1
62	730-1448	STOP, BUMPER, WEIGHT PLATE, 25.4MM	2
63	730-1491	LABEL, INSTRUCTIONS, LOCK N LOAD	1
64	730-1537	KIT, REPLACEMENT, ADJ. LEG, LEG EXT.	1

UNISEN, INC. DBA
STARTRAC
 14410 Myford Road
 Irvine CA 92606

STARTRAC PART NO. | REV.
9IL-S1010-13BSS B
 TITLE
IL, SSS, LEG EXT, SIDE MOUNT, LNL
 SCALE: 1:18 | SHEET 2 OF 2 | SHEET SIZE: B